

FALPER ID PORTFOLIO 2023

LIVING BATHROOM™

Design essenziale e pulito, materiali preziosi e innovativi, lavorazioni artigianali di estrema precisione: il Living Bathroom™ di Falper apre le porte a un nuovo modo di vivere l'ambiente bagno. Realizzato con i codici estetici e qualitativi della zona living, il bagno firmato Falper diventa un ambiente fluido, una sintesi armoniosa di funzionalità ed estetica sofisticata. Oggetti dal forte statement e dalle linee raffinate e scultoree, i prodotti sono i veri protagonisti di questo spazio.

Clean, minimal lines, superior and innovative materials, high-precision craftsmanship: the Living Bathroom™ by Falper opens the door to a new way of experiencing the bathroom environment. Created with the aesthetics and qualities of living areas in mind, the Falper bathroom is an elegantly fluid space, a harmonious blend of functionality and sophisticated style. Statement objects with refined, sculptural lines, these products are the real focus of the bathroom space.



falper.

Identità e prestigio Entra a far parte del “Club” Falper

Guarda come tanta bellezza, identità e prestigio possono essere rappresentati, anche in un solo ambiente. Essere concessionari Falper significa essere ambasciatori del marchio nel mercato di riferimento. Entra nel nostro “club”: i nostri dealer possono contare su un’immagine sofisticata, un know-how consolidato che innalza il posizionamento verso i propri clienti.

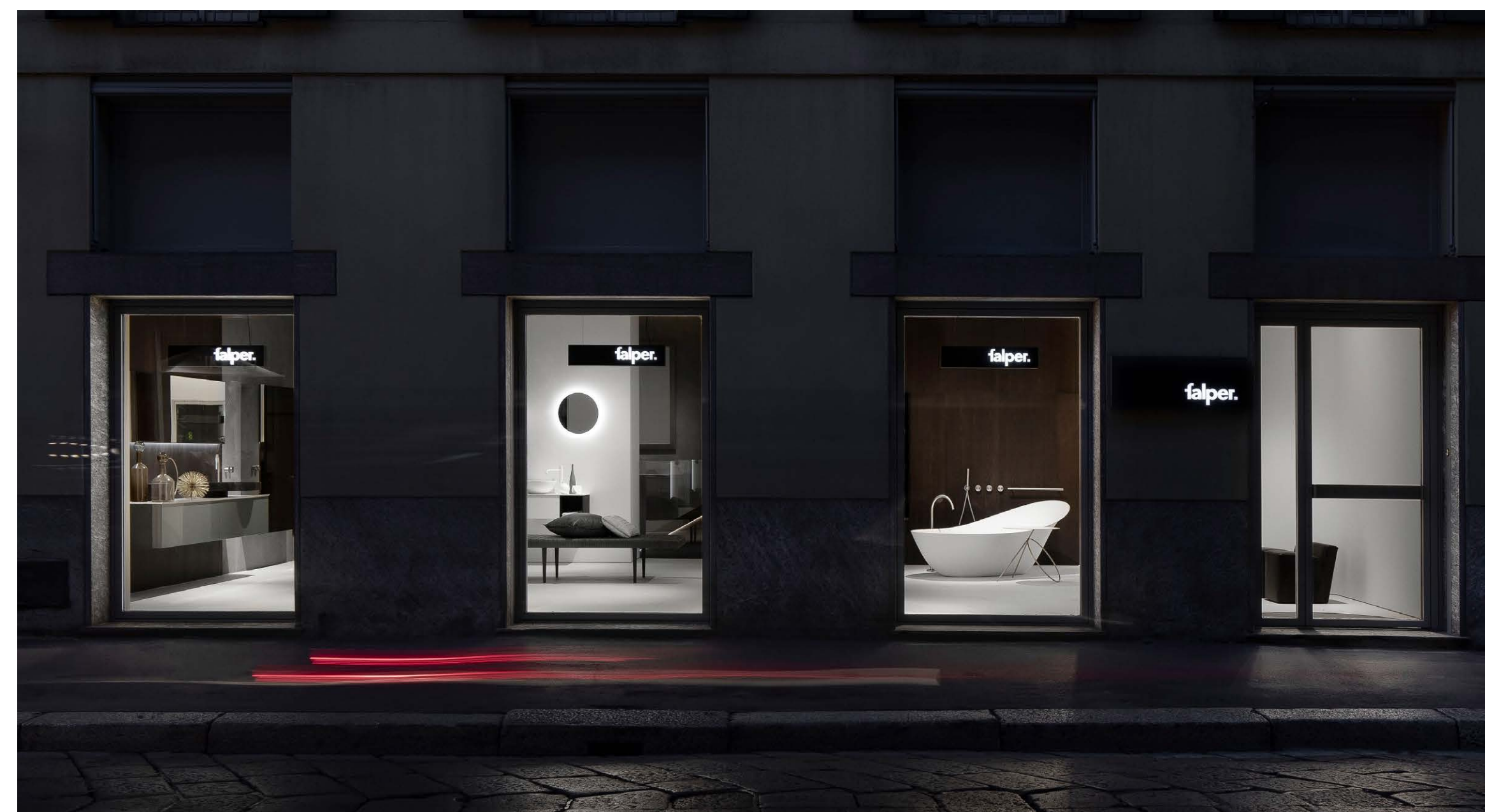

Codice estetico innovativo: il total look dell' ambiente bagno

Il codice estetico dei prodotti Falper rappresenta un prezioso strumento per i nostri dealer, un plus distintivo rispetto alle realtà concorrenti. I nostri rivenditori sono al centro del sistema di gestione delle richieste da parte di clienti e architetti. Accanto a mobili e arredi, il catalogo Falper include un'ampia proposta di complementi, per offrire una gamma completa, innovativa e coerente dell'ambiente bagno.



FALPER ID

Quattro diverse tipologie che si adattano al tuo spazio

Altezza: ideale 2,50, minimo 2,30, massimo 3,00 / Lunghezza e Profondità: ideale 3,60, minimo 3,40, massimo 4,00
I box ID rappresentati sono realizzabili salvo il rispetto delle dimensioni indicate. Nel caso di dimensioni superiori a quelle indicate si prega di richiedere un progetto ad hoc. Non sarà invece possibile realizzare spazi ID al di sotto delle dimensioni minime indicate.

Box

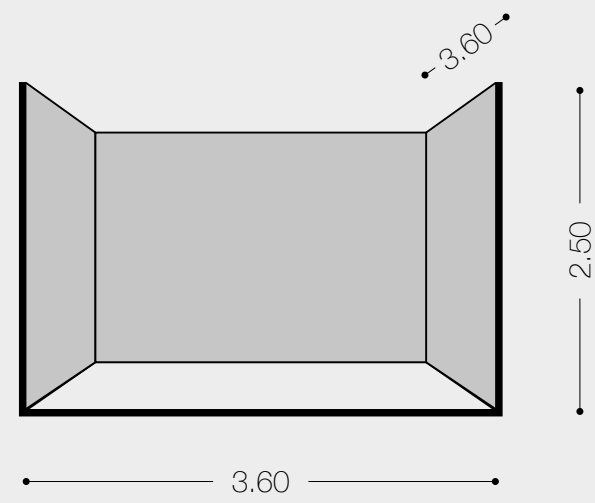

Corner

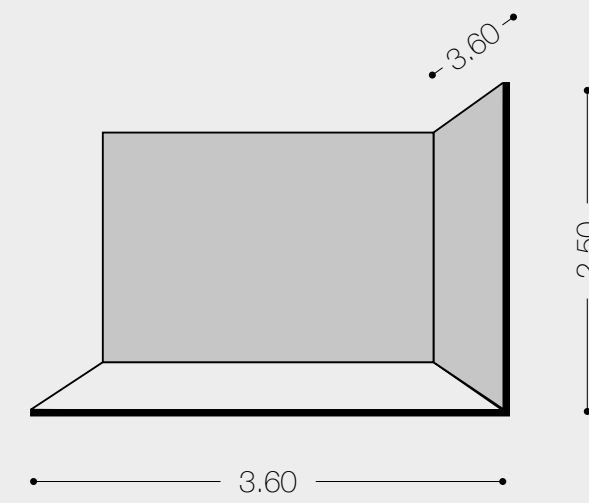

Open Space

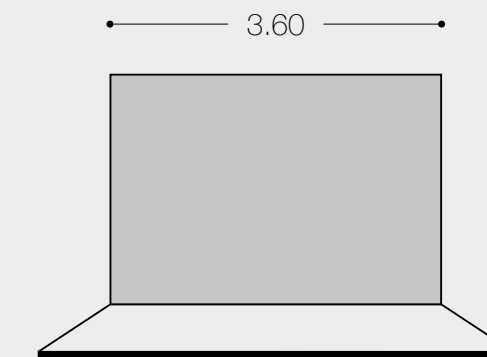

Box Doppio

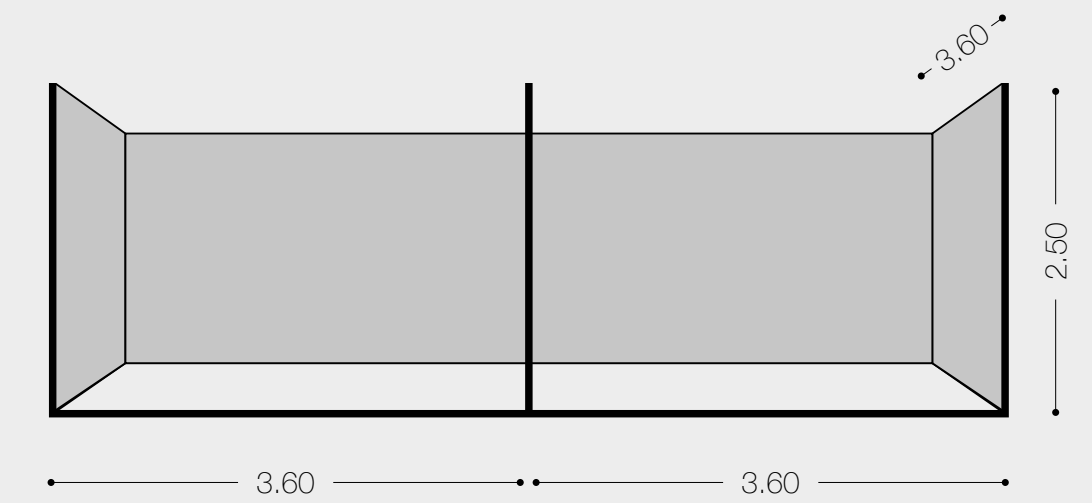

BOX

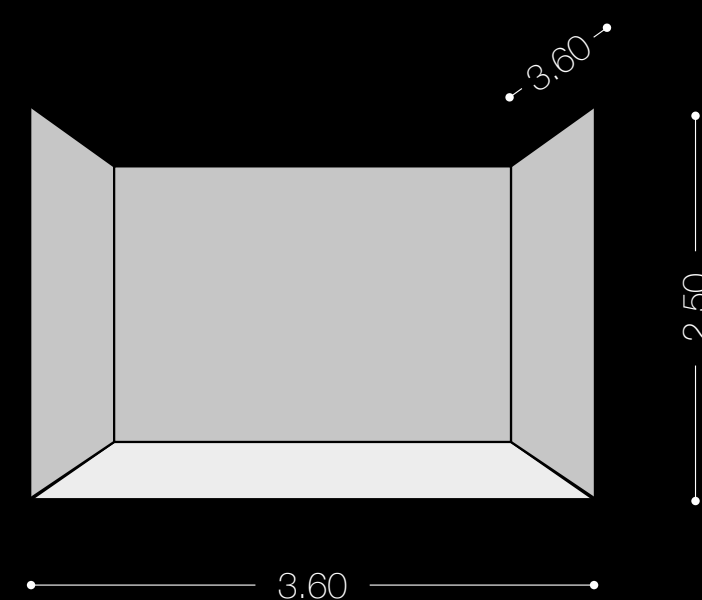

- #B010 Quattro.zero h25 #EF
- #B011 Quattro.zero h25 #ZH
- #B012 Quattro.zero h36 #AX
- #B013 Quattro.zero h50 #3D
- #B020 ViaVeneto G h30 top Arc
- #B021 ViaVeneto G h30 lavabo Fontana
- #B030 ViaVeneto G h45 top Arc
- #B031 ViaVeneto G h45 lavabo Fontana
- #B040 Pure h36 lavabo D8C
- #B041 Pure h36 top Arc
- #B050 Pure h76 lavabo D7H
- #B060 Eccentrico
- #B070 Minimum marmo
- #B080 Minimum cemento
- #B090 Eccentrico freestanding
- #B100 Fontana
- #B110 Homey

FALPER ID

Quattro.Zero





BOX

#B010
Quattro.zero h25 #EF



BOX

#B011
Quattro.zero h25 #ZH



BOX

#B012
Quattro.zero h36 #AX

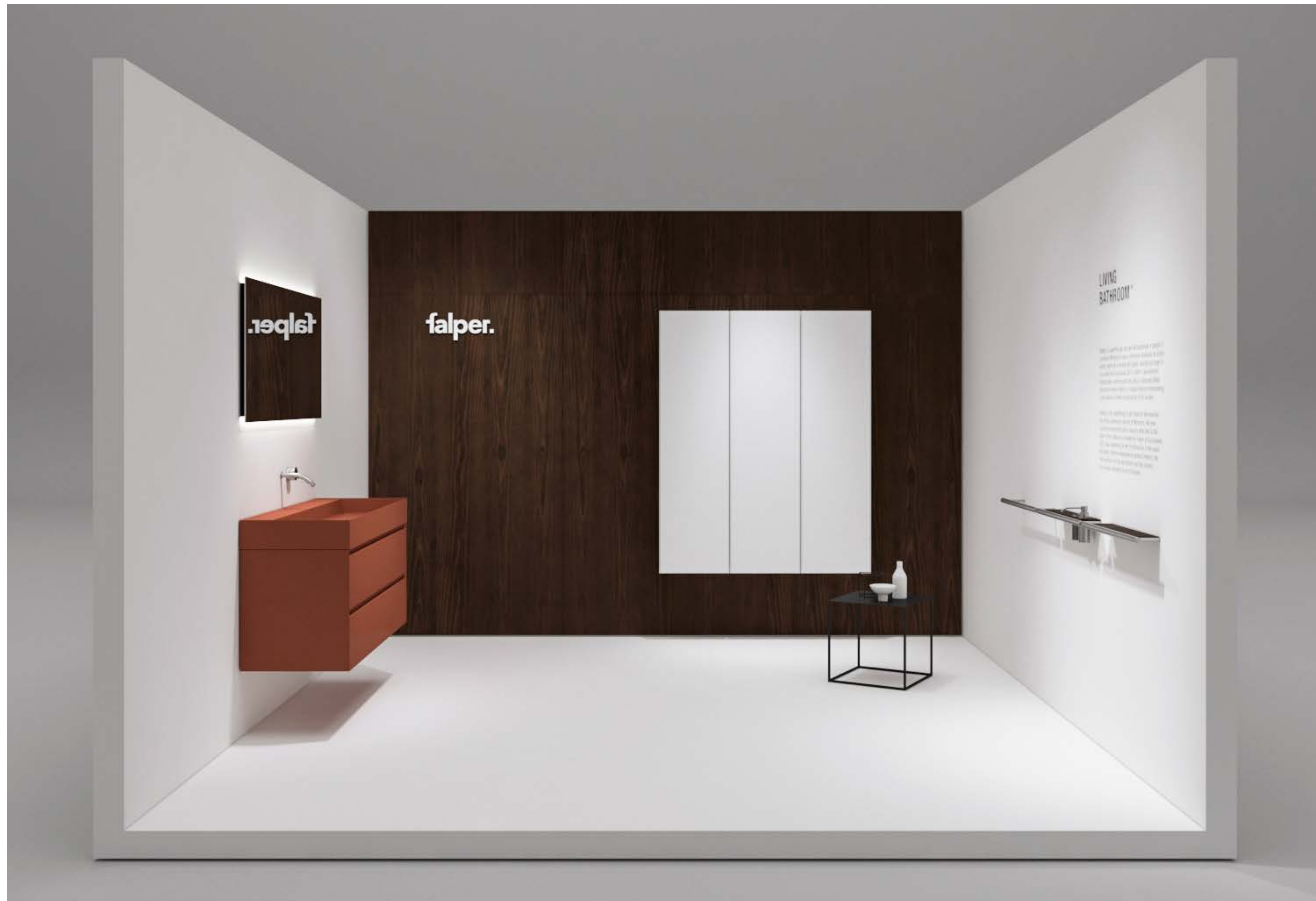

BOX

#B013
Quattro.zero h50 #3D

BOX

#B020
ViaVeneto G h30 top Arc



BOX

#B021
Via Veneto G h30
lavabo Fontana



BOX

#B030

ViaVeneto G h45 top Arc



BOX

#B031
Via Veneto G h45
lavabo Fontana



FALPER ID

Pure





BOX

#B040
Pure h36 lavabo D8C



BOX

#B041
Pure h36 top Arc



BOX

#B050
Pure h76 lavabo D7H

BOX

#B060
Eccentrico



FALPER ID

Minimum e Butler

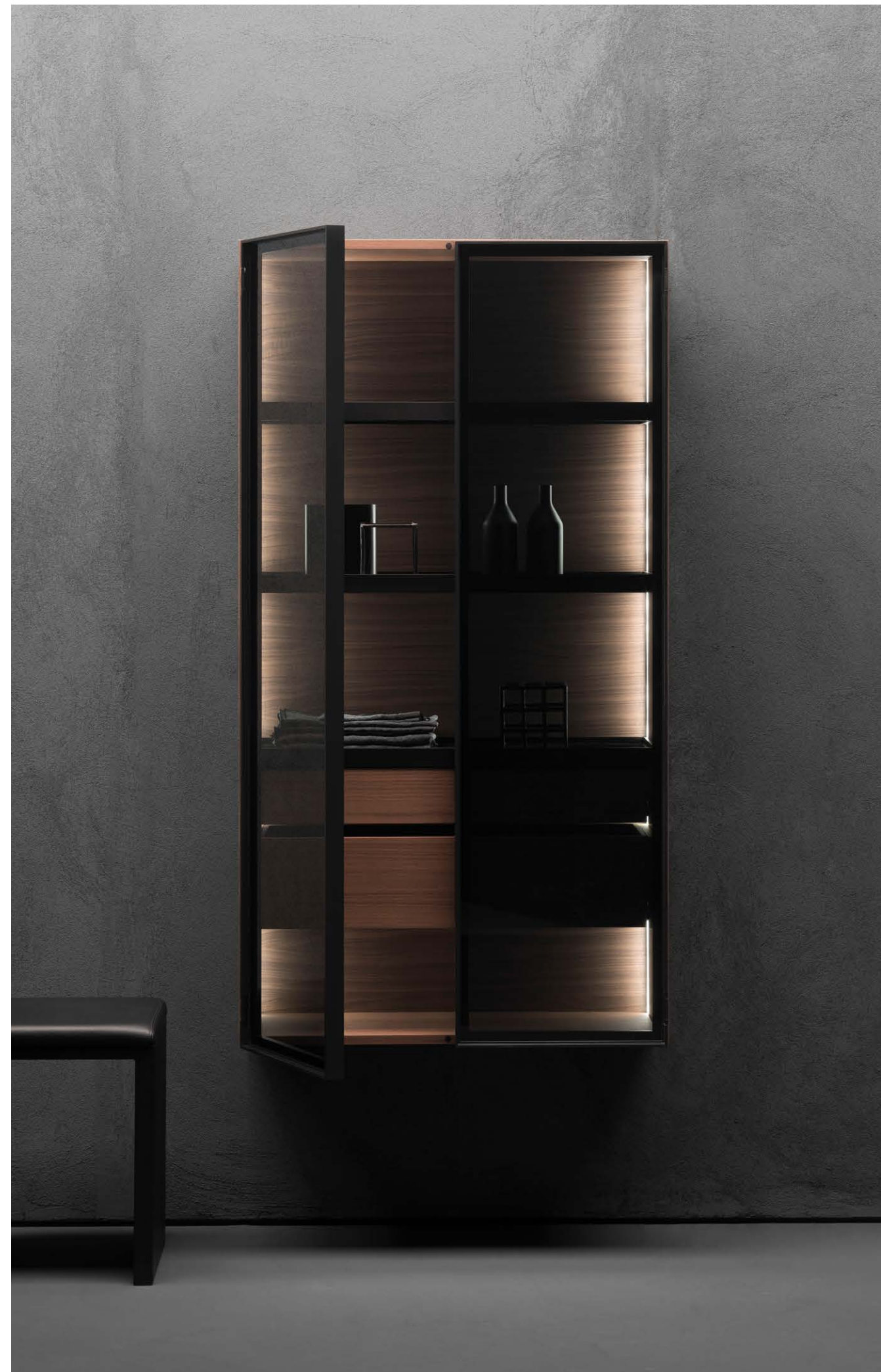

BOX

#B070
Minimum marmo



BOX

#B080
Minimum cemento



BOX

#B090
Eccentrico freestanding





BOX

#B100
Fontana



BOX

**#B110
Homey**

CORNER

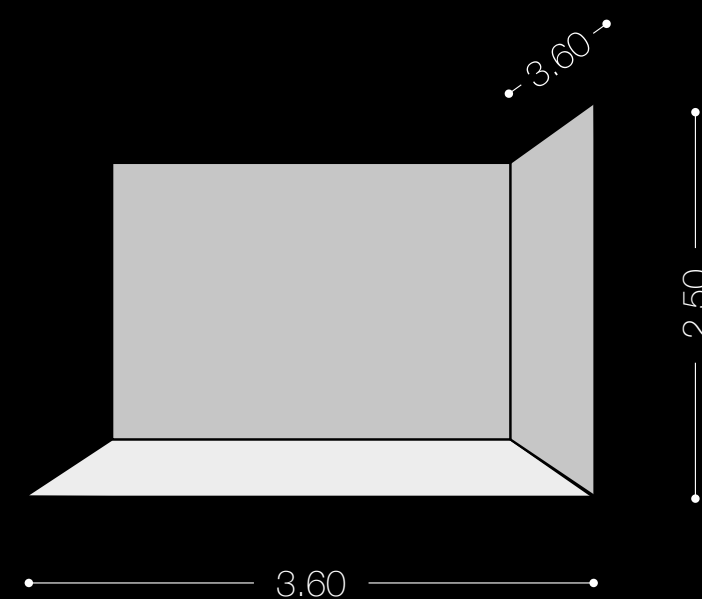

- #C010 Quattro.zero h25 #EF
- #C011 Quattro.zero h25 #ZH
- #C012 Quattro.zero h36 #AX
- #C013 Quattro.zero h50 #3D
- #C020 ViaVeneto G h30 top Arc
- #C021 ViaVeneto G h30 lavabo Fontana
- #C030 ViaVeneto G h45 top Arc
- #C031 ViaVeneto G h45 lavabo Fontana
- #C040 Pure h36 lavabo D8C
- #C041 Pure h36 top Arc
- #C050 Pure h76 lavabo D7H
- #C060 Eccentrico
- #C070 Minimum marmo
- #C080 Minimum cemento
- #C090 Eccentrico freestanding
- #C100 Fontana
- #C110 Homey



CORNER

#C010
Quattro.zero h25 #EF



CORNER

#C011
Quattro.zero h25 #ZH



CORNER

#C012
Quattro.zero h36 #AX



CORNER

#C013
Quattro.zero h50 #3D

FALPER ID

Via Veneto



CORNER

#C020
ViaVeneto G h30 top Arc



CORNER

#C021
Via Veneto G h30
lavabo Fontana



CORNER

#C030
ViaVeneto G h45 top Arc



CORNER

#C031
Via Veneto G h45
lavabo Fontana





CORNER

#C040
Pure h36 lavabo D8C



CORNER

#C041
Pure h36 top Arc



CORNER

#C050
Pure h76 lavabo D7H

CORNER

#C060
Eccentrico



CORNER

#C070
Minimum marmo



CORNER

#C080
Minimum cemento



CORNER

#C090
Eccentrico freestanding





CORNER

#C100
Fontana

FALPER ID

Homey





CORNER

#C110
Homey

OPEN SPACE

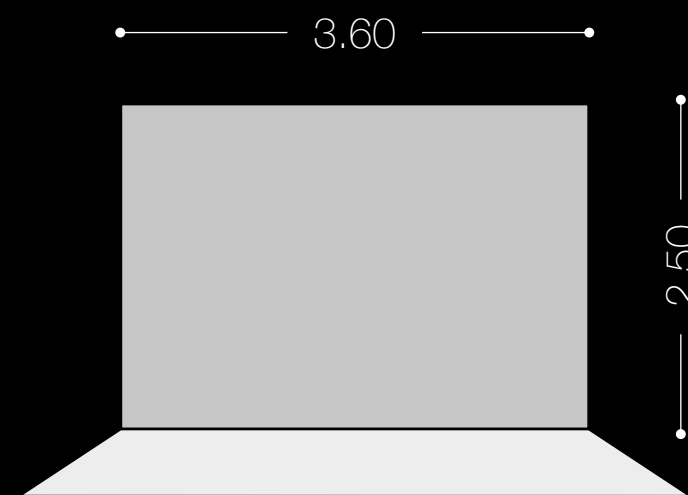

- #S060 Eccentrico
- #S070 Minimum marmo
- #S080 Minimum cemento
- #S090 Eccentrico freestanding
- #S100 Fontana
- #S110 Homey

OPEN SPACE

#S060
Eccentrico



OPEN SPACE

#S070
Minimum marmo



OPEN SPACE

#S080
Minimum cemento



OPEN SPACE

#S090
Eccentrico freestanding

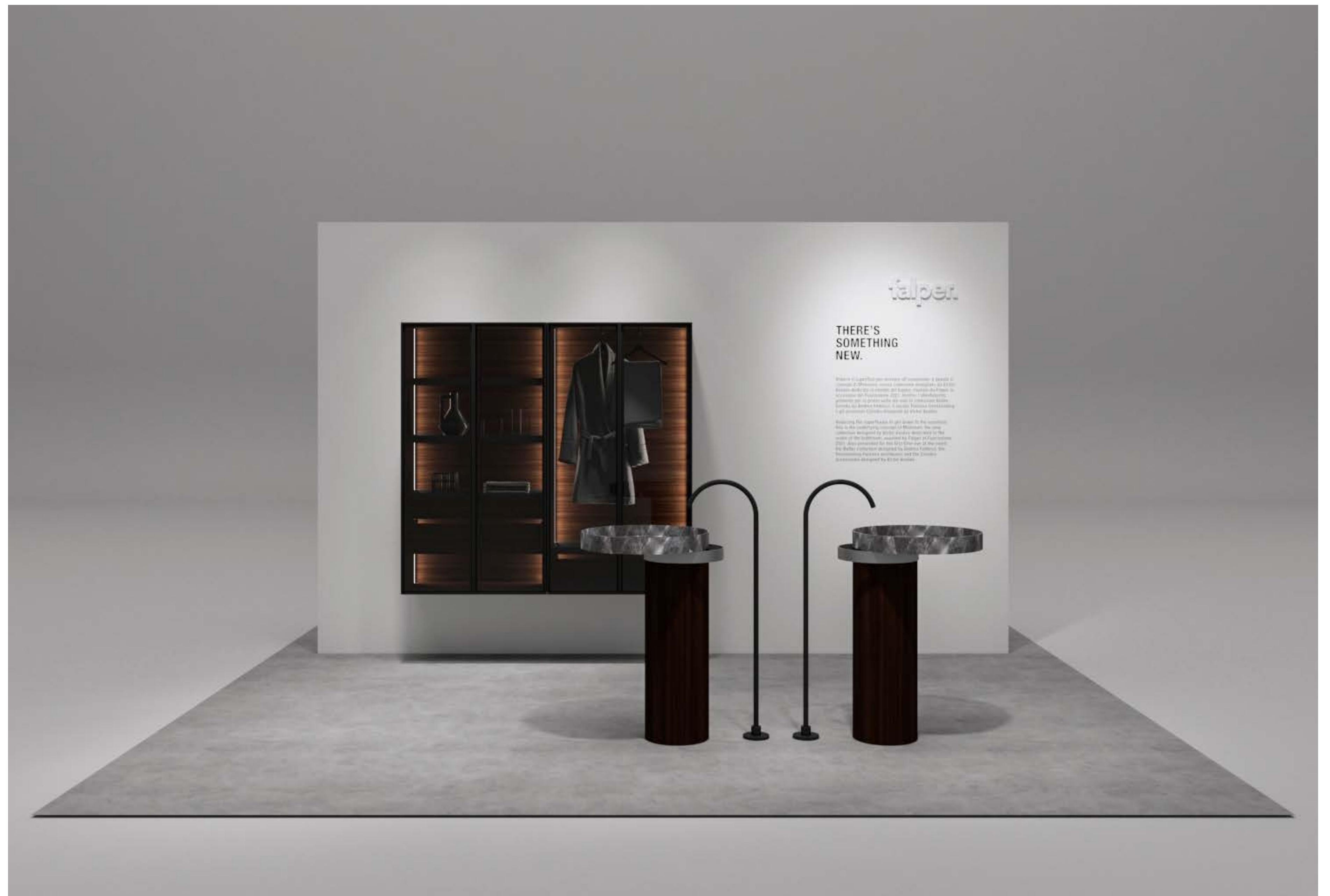

OPEN SPACE

#S100
Fontana



OPEN SPACE

#S110
Homey

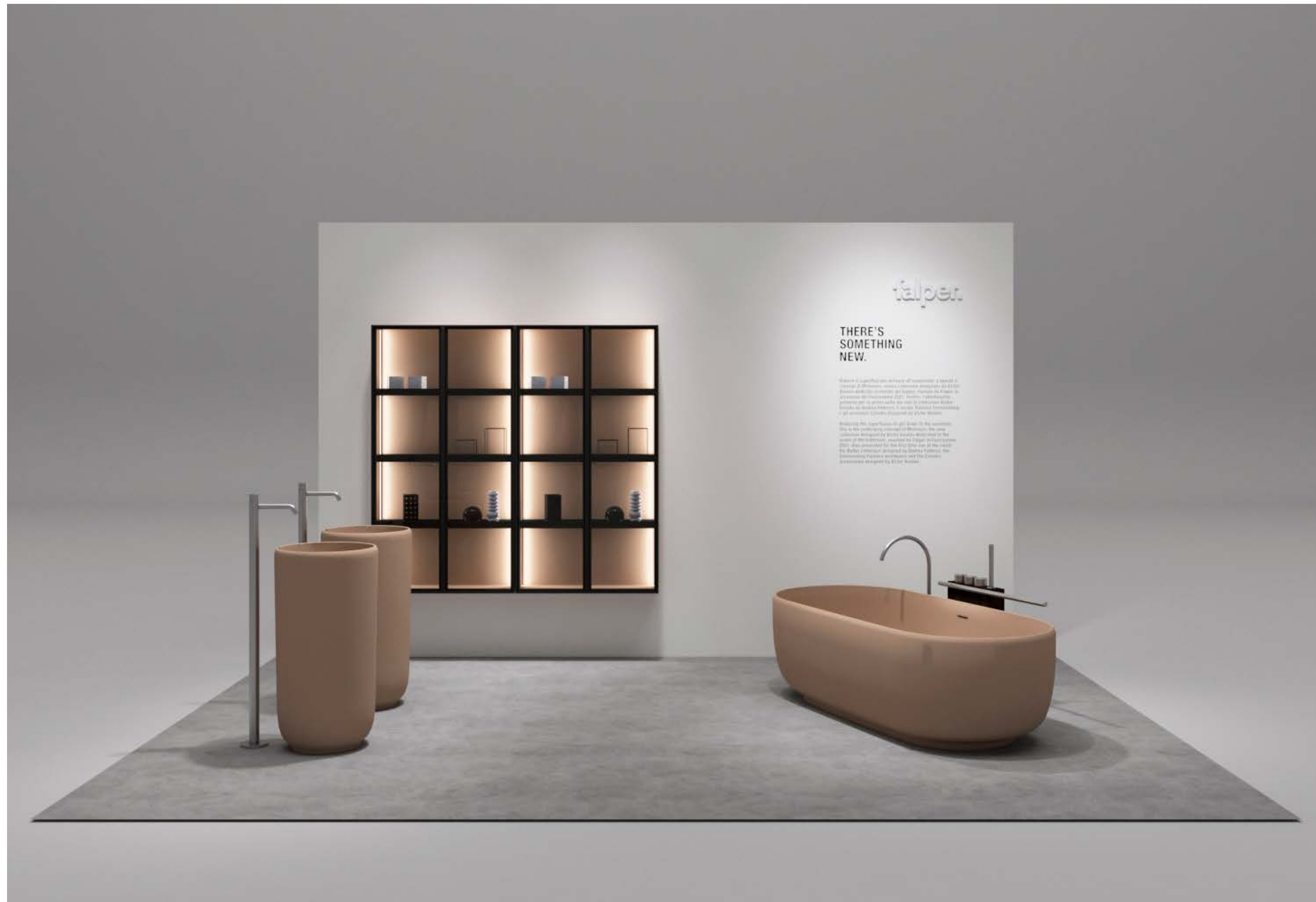

BOX DOPPIO

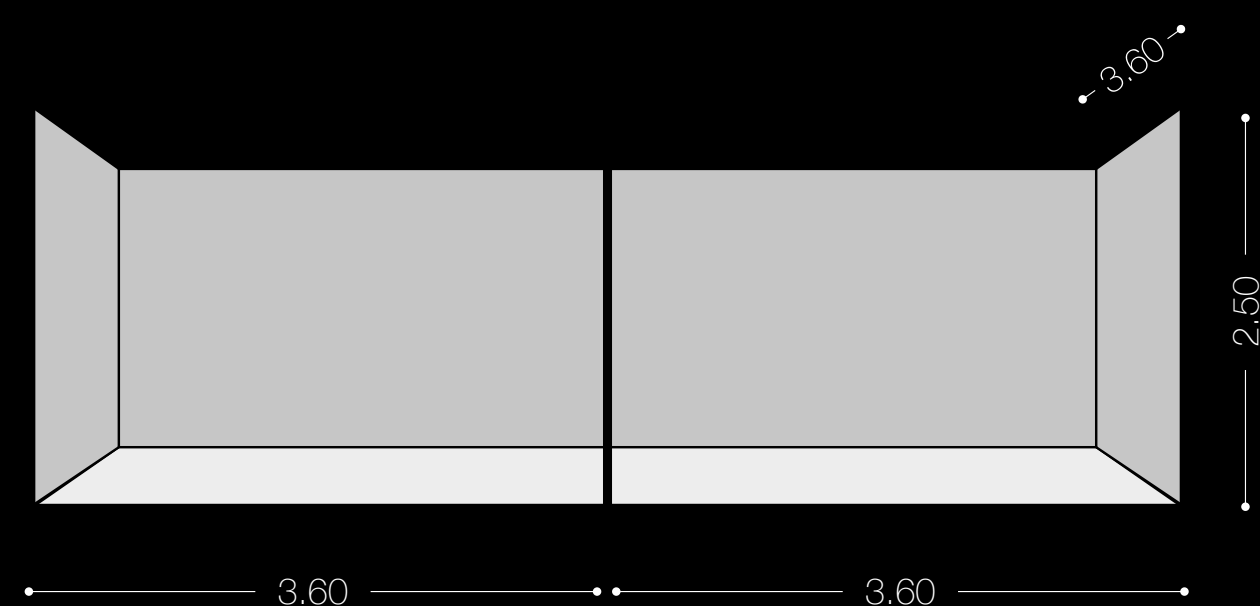

- #Z010 7.0 h25 + Quattro.zero h25
- #Z020 ViaVeneto G h30 + Quattro.zero h25
- #Z030 Pure h76 + Quattro.zero h25
- #Z040 Minimum cemento + Quattro.zero h25
- #Z050 Eccentrico + Quattro.zero h25
- #Z060 Eccentrico + Pure h36
- #Z070 Fontana + Quattro.zero h25
- #Z080 Pure h76 + Homey
- #Z090 Minimum cemento + Eccentrico freestanding



BOX DOPPIO

#Z010
7.0 h25 +
Quattro.zero h25



BOX DOPPIO

#Z010
7.0 h25 +
Quattro.zero h25



BOX DOPPIO

#Z020
ViaVeneto G h30 +
Quattro.zero h25



BOX DOPPIO

#Z020
ViaVeneto G h30 +
Quattro.zero h25



BOX DOPPIO

#Z030
Pure h76 +
Quattro.zero h25



BOX DOPPIO

#Z030
Pure h76 +
Quattro.zero h25

BOX DOPPIO

#Z040
Minimum cemento +
Quattro.zero h25



BOX DOPPIO

#Z040
Minimum cemento +
Quattro.zero h25



BOX DOPPIO

#Z050
Eccentrico +
Quattro.zero h25



BOX DOPPIO

#Z050
Eccentrico +
Quattro.zero h25



BOX DOPPIO

#Z060
Eccentrico +
Pure h36



BOX DOPPIO

#Z060
Eccentrico +
Pure h36



BOX DOPPIO

#Z070
Fontana +
Quattro.zero h25



BOX DOPPIO

#Z070
Fontana +
Quattro.zero h25





BOX DOPPIO

#Z080
Pure h76 +
Homey



BOX DOPPIO

#Z080
Pure h76 +
Homey



BOX DOPPIO

#Z090
Minimum cemento +
Eccentrico freestanding



BOX DOPPIO

#Z090
Minimum cemento +
Eccentrico freestanding

LINEE GUIDA ALLESTIMENTO

Finiture

Bianco – Idropittura bianco RAL 9003



Finiture suggerite
HD SURFACE - Perfect Combination, colore Bianco 01
KERAKOLL - Wallpaper, colore KK1 Color Collection
OIKOS PAINT – Supermatt

Cemento – Resina, intonachino o tinteggiatura effetto cemento.



Finiture suggerite:
HD SURFACE - Cemento Wabi, colore Grey 112
KERAKOLL - Wallcrete, colore KK8 Color Collection
OIKOS PAINT - Cemento Materico, texture Industriale, colore CE 1002
CANDIS - Forma, colore Iron Grey 390

Boiserie – Rivestimento in legno di Acacia termo-trattata



Realizzata su misura e fornita da Falper.
Da installare secondo indicazioni progettuali.

**Saremo lieti di incontrarvi di persona
per una collaborazione di successo.**

Info:
marketing@falper.it

falper.