

**NEW
S-20
26**

falper.

Solid and tactile, the
Marble defines the
base with elegance,
while Murano *blown*
Glass cradles the water,
enhancing its light,
depth, and transparency.





Mono, precise in form and perfectly proportioned, it expresses a unique harmony where every line and surface meets in quiet balance.

News 2026 Index

Viaveneto Stone – p.08
by Falper Design



Stone Built-in basins
by Falper Design



Ego Fold – p.70
by Massimo Castagna



Lens – p.76
by Massimo Castagna



Ratio – p.84
by Massimo Castagna



Maestro – p.26
by Massimo Castagna



Cavo – p.44
by Massimo Castagna



Invaso Stone – p.94
by Falper Design



Goccia – p.102
by Massimo Castagna



Mono – p.58
by Foster+Partners Industrial Design



Boiserie – p.108
by Falper Design



Viaveneto Stone

by Falper Design

Viaveneto Stone combines the authentic charm of natural stone with clean lines and suspended volumes, creating a sophisticated, striking, and contemporary bathroom space.

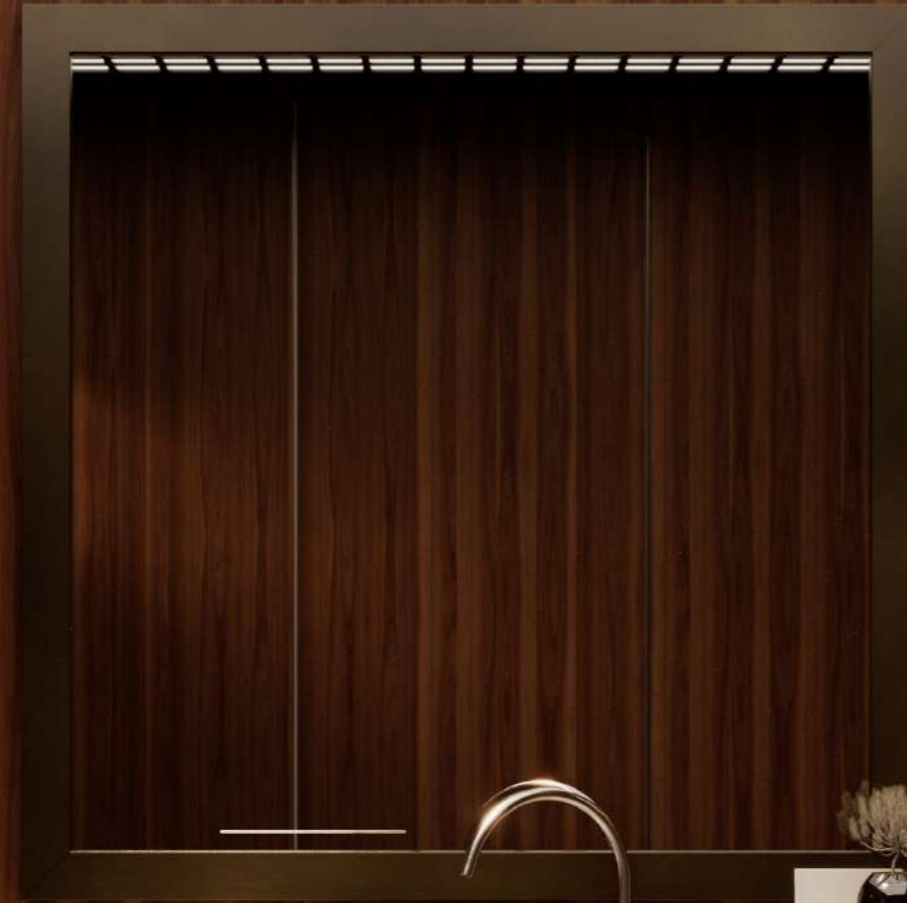

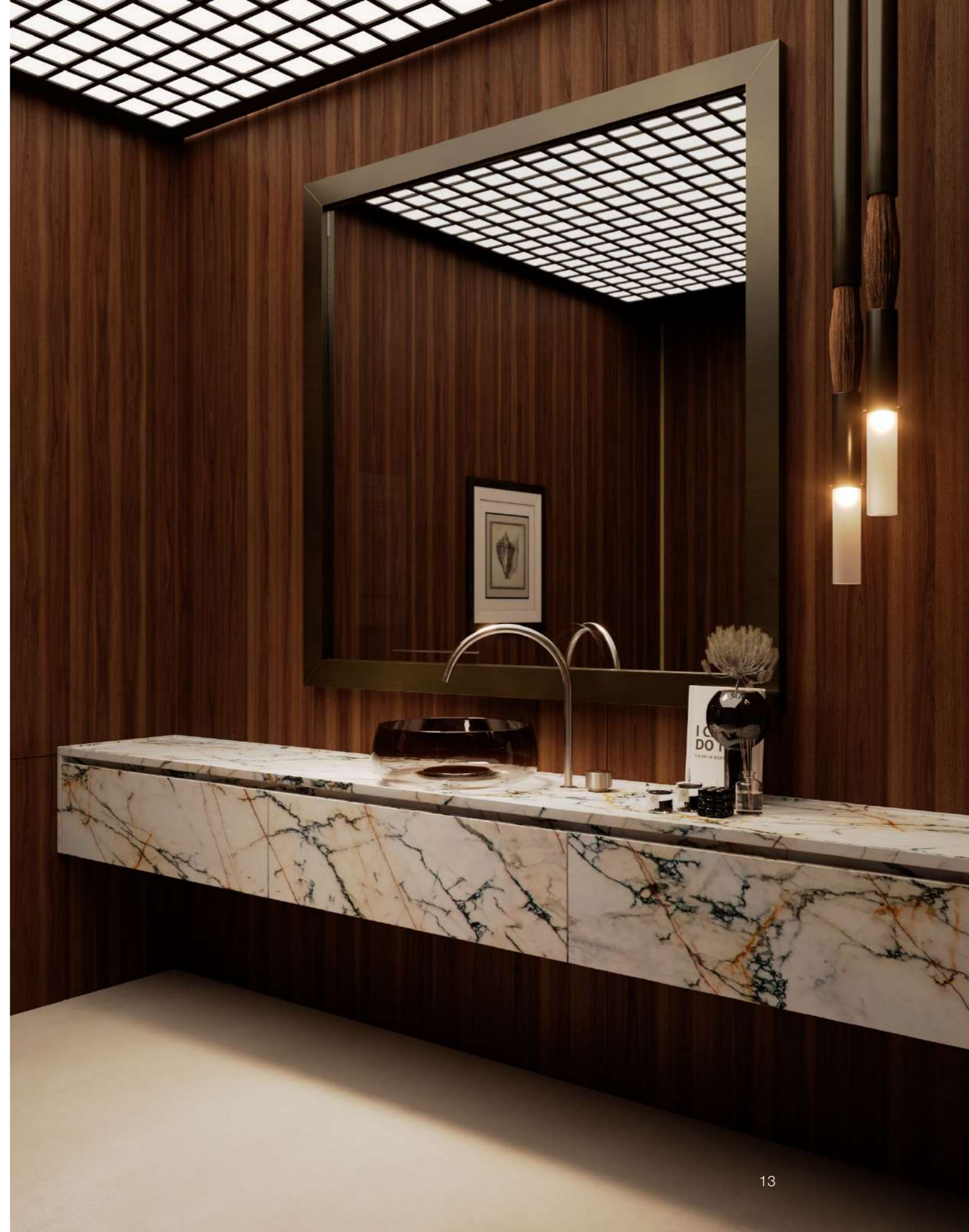
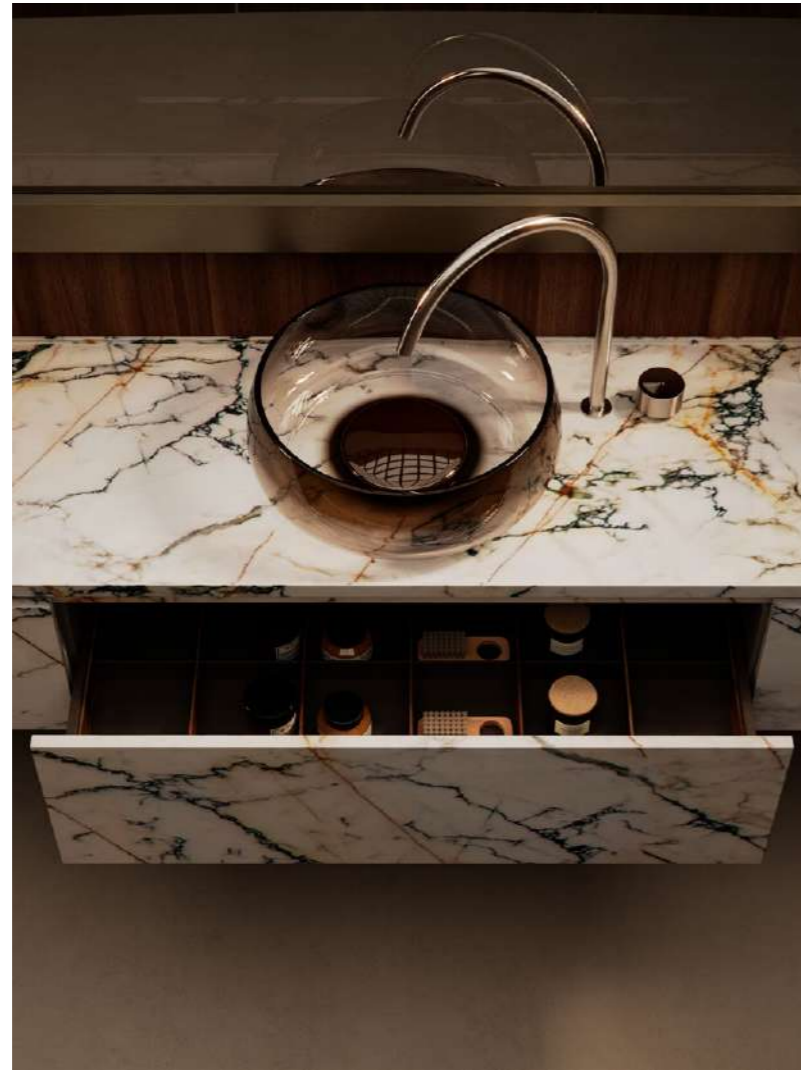



Technical Sheets

H 30 cm
P 45/55 cm
L 60-80-90-100 cm

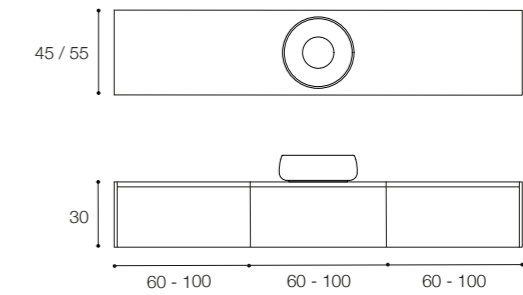

^(*) Mobile componibile con frontali dei cassetti e fianchi in marmo Paonazzo Venato. Il top, realizzato nella stessa pietra, è completato da un pratico bordo salvagoccia. Lavabo d'appoggio "Maestro" in vetro di Murano.

^(**) Modular cabinet with drawer fronts and sides in Paonazzo Venato marble. The top, crafted from the same stone, features a practical raised edge to prevent water overflow. "Maestro" countertop washbasin in Murano glass.



Front panels carved with linear grooves from solid material, an optional feature within Viaveneto Stone, enriching surfaces with craftsmanship, depth, and distinctive character.





Technical Sheets

H 30 cm
P 45/55 cm
L 60-80-90-100 cm

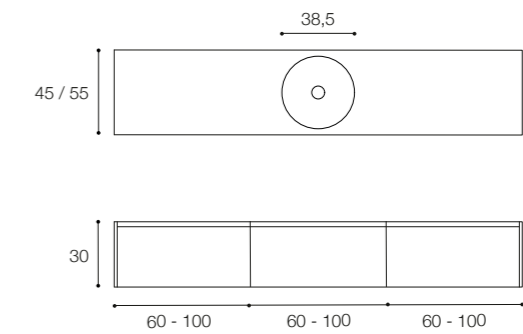

^(IT) Mobile componibile con frontali e fianchi in Travertino Sibillino. Il top con lavabo integrato "Alveo" completa la composizione, valorizzando la matericità della pietra e la purezza delle linee

^(EN) Modular cabinet with fronts and sides in Sibillino Travertine. The top with integrated "Alveo" washbasin completes the composition, enhancing the stone's material character and the purity of its lines.





Technical Sheets

H 30 cm
P 45/55 cm
L 60-80-90-100 cm

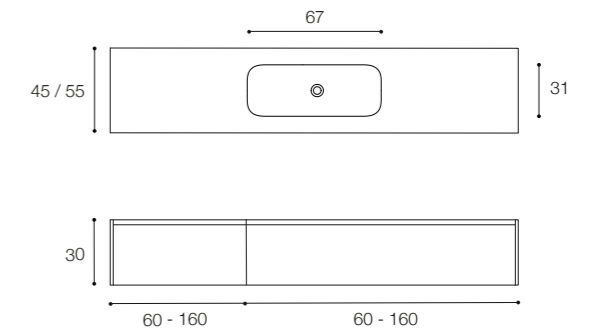

^(FR) Mobile componibile in Noce Canaletto con venatura "Bilia". Il top con lavabo integrato in marmo Tundra Grey modello "Round Soft" completa la composizione, creando un raffinato equilibrio tra il calore del legno e l'eleganza materica della pietra.

^(EN) Modular cabinet in Canaletto walnut with "Bilia" grain. The top with integrated "Round Soft" washbasin in Tundra Grey marble completes the composition, creating a refined balance between the warmth of wood and the material elegance of stone.

Maestro

by Massimo Castagna

A basin named after Murano masters, never identical, with hues and forms pushing blown glass limits, also reimagined in solid surface and marble.





⁽¹⁷⁾ La lavorazione del vetro soffiato in stampo di legno è un processo ultracentenario che rende ogni elemento frutto dell'inimitabile capacità artistica del maestro vetraio che lo realizza. Il design di Massimo Castagna è un incontro di forme, pensiero e materia. Non un prodotto di serie, ma un'eccellenza del Made in Italy.

⁽¹⁸⁾ Blown glass crafted in wooden moulds is a centuries-old process that makes each piece the result of the glass master's inimitable artistic skill. The design by Massimo Castagna is a meeting of form, thought and material. Not a mass-produced item, but an excellence of Made in Italy.

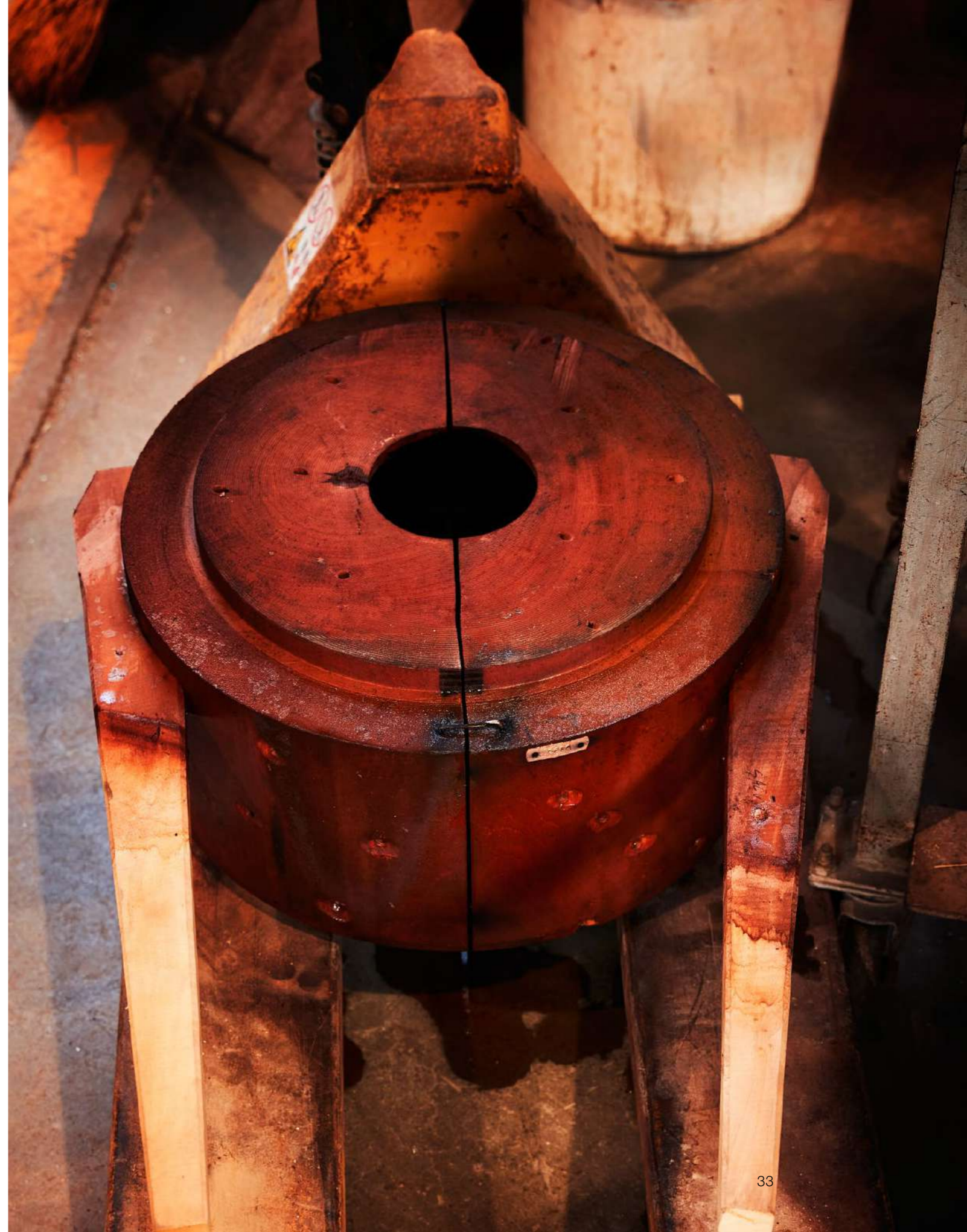



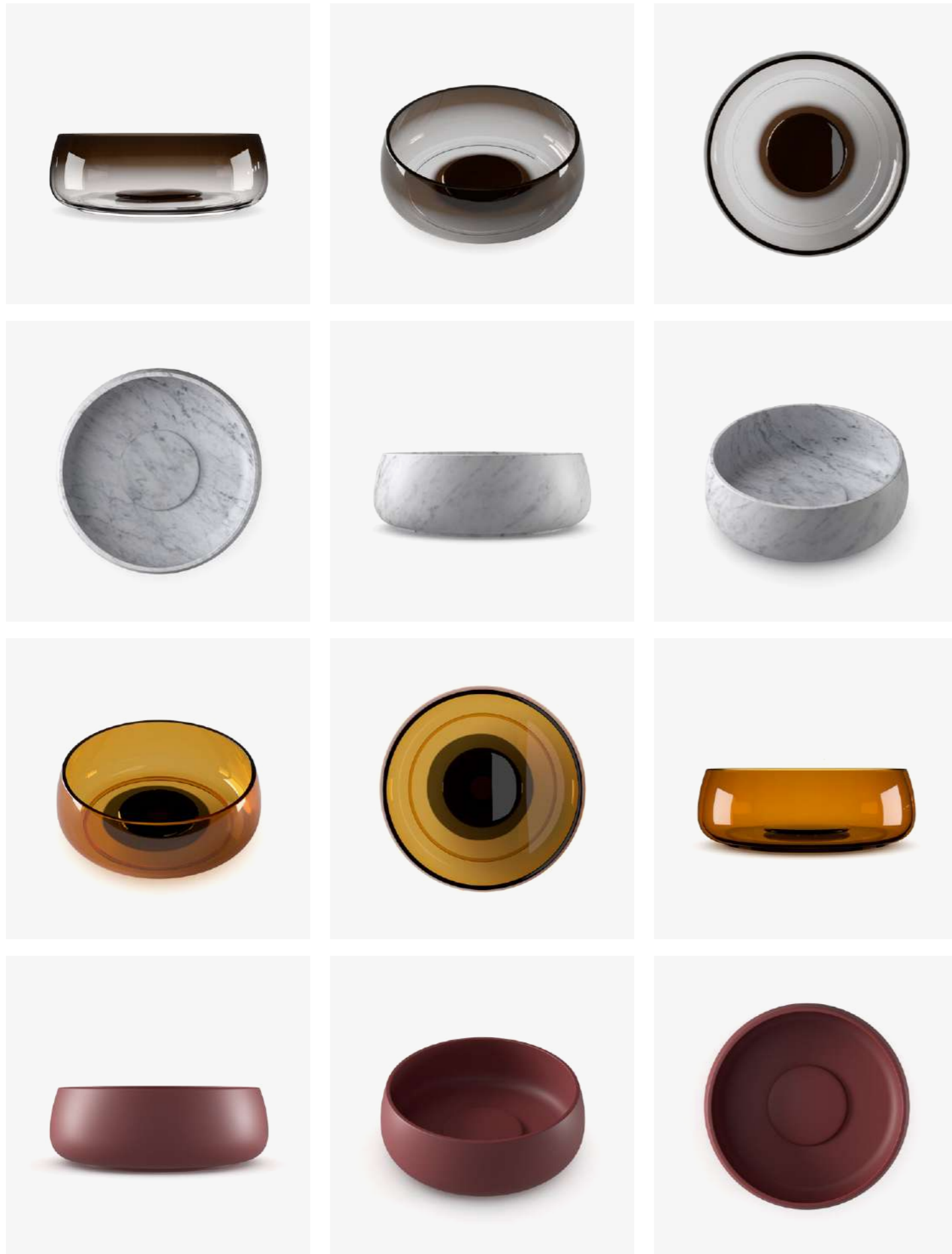

“Maestro” is an idea of absolute lightness: glass, light and matter come together in an essential form, made unique by the large glass waste cover, a distinctive feature of the design.

^(IT) Maestro è disponibile in vetro, marmo e Cristalplant Bio Active. Un lavabo dalle forme morbide, caratterizzato da una grande piletta, elemento distintivo che ne definisce l'estetica con forte personalità.

^(EN) Maestro is available in glass, marble and Cristalplant Bio Active. A washbasin with soft shapes, distinguished by a large waste cover, a defining feature that gives the design a strong identity.





Maestro interprets the washbasin as an exclusive furnishing object: enveloping proportions, flawless surfaces and a striking presence that expresses discreet luxury and sophisticated contemporaneity.

Technical Sheets

H 14 cm

P 41 cm

L 41 cm

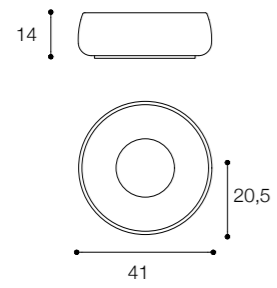

Finiture / Finishes

Vetro soffiato di Murano | Murano blown glass

Sfumato Marrone | shaded Brown

Ambra Colore | Amber Color

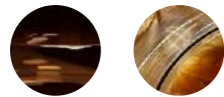

Cristalplant Bio Active

Cristalplant Colors



Marmo | Marble



Cavo

by Massimo Castagna

Sculpted from marble,
basin reveals organic
depth, irregular
textures and balanced
proportions, where
natural fragments and
polished surfaces create
quiet, timeless elegance.





Washbasin carved from solid marble, where the strength of the material meets the purity of design. Its natural veining makes each piece exclusive, expressing authentic, timeless luxury.



^(IT) La lavorazione del marmo dal pieno è un processo che trasforma la materia naturale in manufatto, esaltandone finitura, forma, spessore e calore. CAVO prende il nome da una forma appena modellata, essenziale e materica. Non un prodotto di serie, ma un'eccellenza del Made in Italy.

^(EN) Carved from solid marble, the process transforms raw material into a refined object, enhancing its finish, form, thickness and warmth. CAVO takes its name from a barely shaped, essential and material form. Not a mass-produced item, but an excellence of Made in Italy.





⁽¹⁷⁾ Lavabo Cavo in appoggio su mobile componibile della collezione Essenza. La rubinetteria della serie Acquifero in acciaio inox Aisi 316 completa un mobile dal rigore sofisticato, dove equilibrio formale, matericità ricercata e dettagli essenziali definiscono un'eleganza contemporanea.

⁽¹⁸⁾ Cavo countertop washbasin set on a modular cabinet from the Essenza collection. The Acquifero tapware series in AISI 316 stainless steel completes a piece defined by sophisticated rigor, where formal balance, refined materiality and essential details express a contemporary elegance.

Technical Sheets

H 12 cm
P 48 cm
L 48 cm

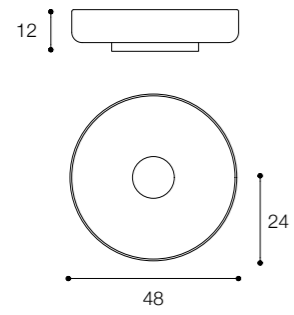

Finiture / Finishes

Marmo / Marble

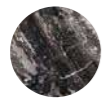

Mono

by Foster+Partners Industrial Design

Bathroom collection
with sculptural,
sophisticated character,
where continuous
forms, harmonious
surfaces and refined
proportions balance
function, materiality,
and contemporary
architectural sensibility.





^(IT) Mobile bagno freestanding con doppio cassetto, realizzato in essenza di noce naturale, con maniglie in finitura onice e lavabo in marmo bianco di Carrara. MONO è sintesi di armonia e funzione.

^(EN) Freestanding bathroom cabinet with double drawers, crafted in natural walnut, with onyx-finish handles and a white Carrara marble basin. MONO is a synthesis of harmony and function.





“ The team studied the relationships between functional shapes, planes and surfaces, balancing and unifying these elements into continuous crafted forms. „

Foster+Partners Industrial Design



Technical Sheets

Washbasin	Freestanding
H 12 cm	H 76 cm
P 45 cm	P 45 cm
L 90 cm	L 90 cm

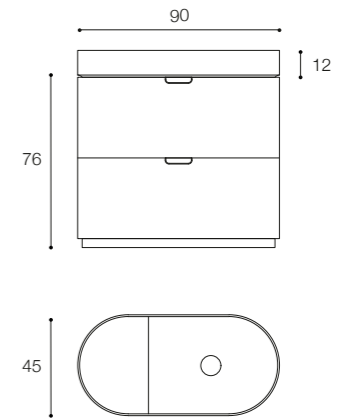

⁽¹¹⁾ Base freestanding con due cassetti e lavabo integrato. Disponibile anche con frontali in legno rigato nell'essenza noce, è completata dal lavabo in Cristalplant Bio Active, materiale che unisce praticità, pulizia formale e qualità contemporanea.

^(EN) Freestanding base unit with two drawers and an integrated washbasin. Also available with fluted Canaletto walnut fronts, it is completed by a Cristalplant Bio Active washbasin, a material that combines practicality, clean lines and contemporary quality.

Ego Fold

by Massimo Castagna

A sophisticated mirror
designed to enhance
the space through
formal balance, essential
design, and natural
contemporary elegance.



Technical Sheets

L 150-170-190-210 cm
H 100 cm
P 2,5 cm

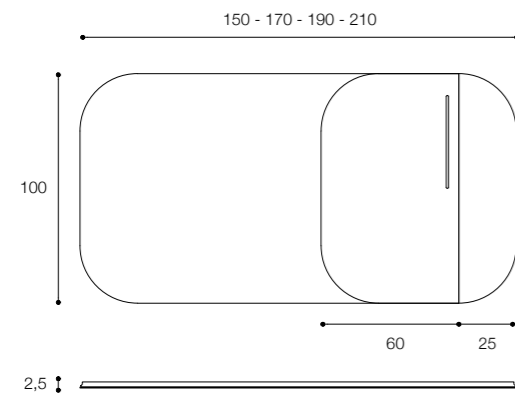

Finiture / Finishes

Bronzo e Chiaro
Bronze and Light



^(IT) Ego Fold nasce dall'incontro di due specchi nelle tonalità bronzo ed extra chiaro, accostati in un equilibrio di grande raffinatezza. La pratica anta pieghevole ne arricchisce la funzionalità, trasformandolo in un elemento distintivo che unisce eleganza decorativa e uso quotidiano.

^(EN) Ego Fold is created through the combination of two mirrors in bronze and extra clean, paired in a composition of refined elegance. The practical folding door enhances its functionality, turning it into a distinctive element that combines decorative sophistication with everyday use.

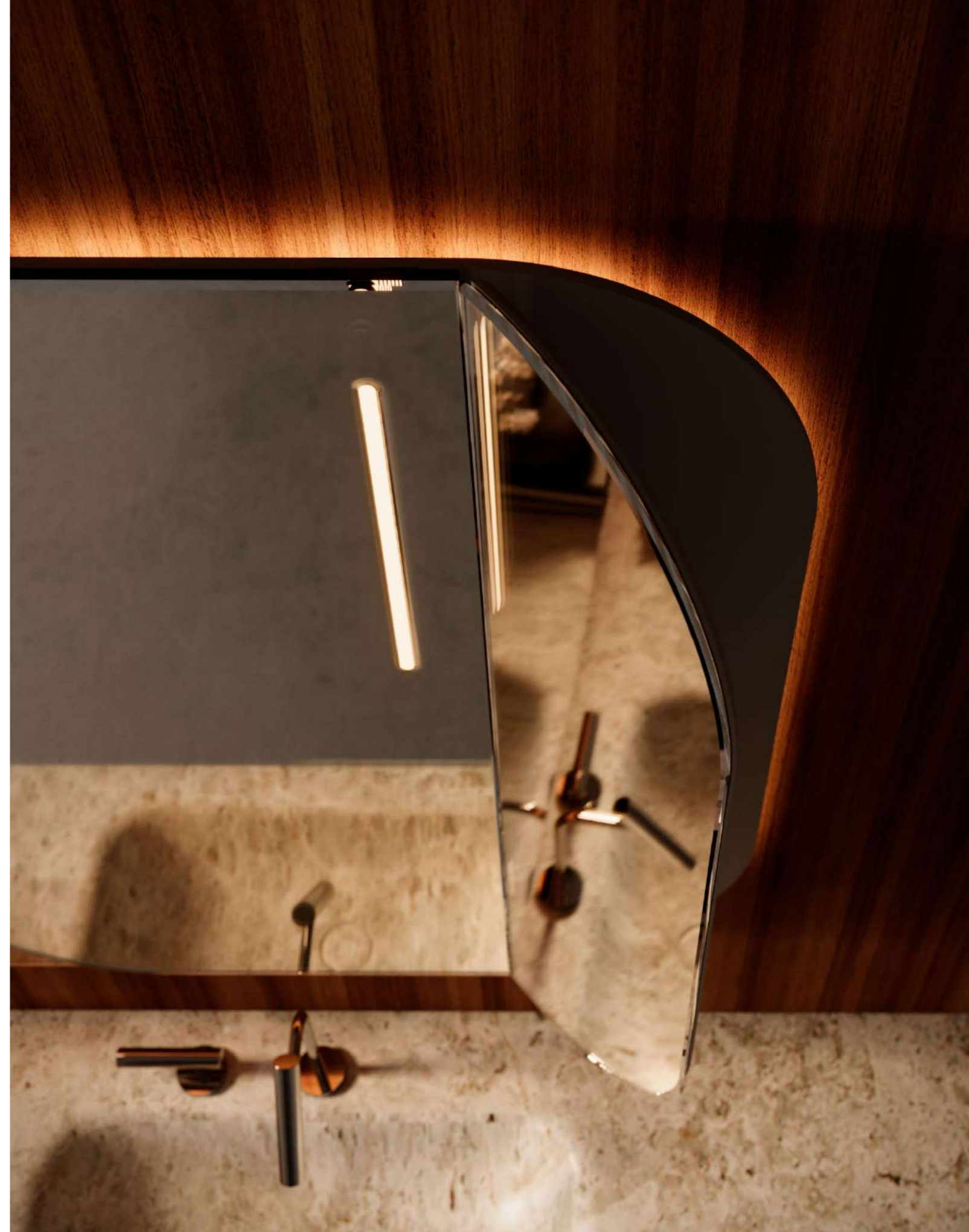

Lens

by Massimo Castagna

A vertically organic mirror, curved along its entire perimeter, a reflective sculpture designed to be admired, and to admire oneself in its form.

^(IT) Specchio Lens verticale, dalla forma organica pensata per dialogare con elementi freestanding. Unione di funzione e sofisticazione, dove specchio e arte convivono. Disponibile in vetro bronzo, fumé grigio o extra chiaro, con illuminazione LED sul retro. Lavabo freestanding Eccentrico, by Victor Vasilev.

^(EN) Lens vertical mirror, featuring an organic shape designed to interact with freestanding elements. A fusion of function and sophistication, where mirror and art coexist. Available in bronze, grey smoked or extra-clear glass, with rear LED lighting. Freestanding washbasin Eccentrico, by Victor Vasilev.



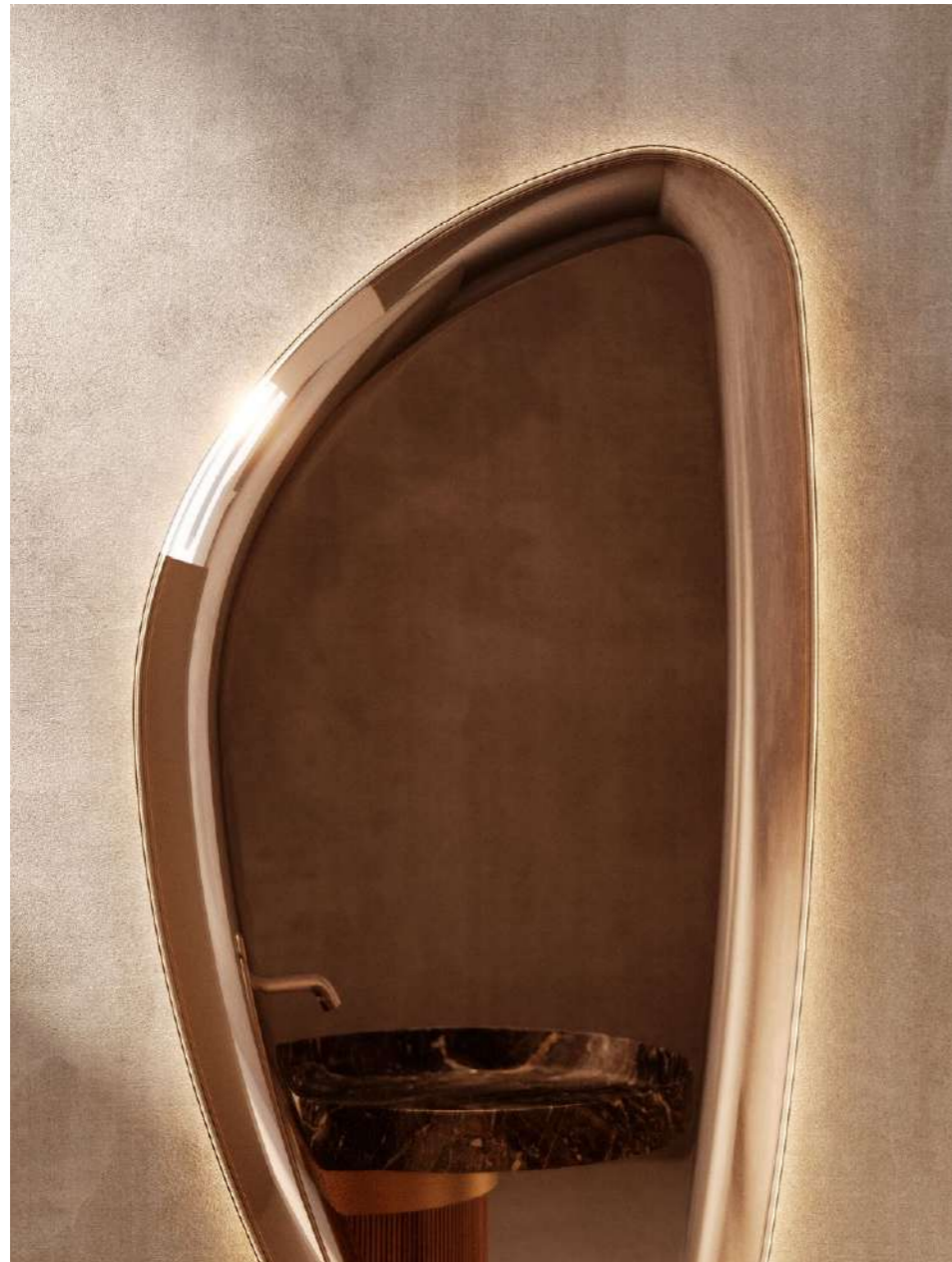

“ I wanted this mirror to dissolve boundaries between object and reflection, becoming a living sculpture that transforms space and invites a deeply personal interaction. „

Massimo Castagna

Technical Sheets

L 69,5 cm
H 153 cm
P 5,5 cm

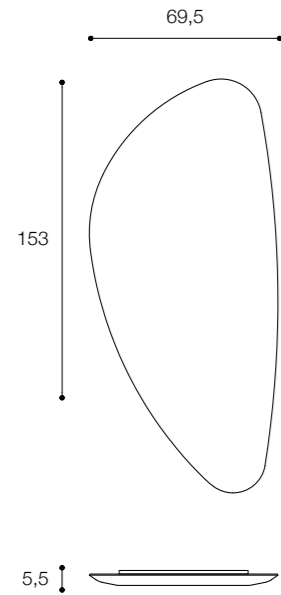

Finiture / Finishes

Chiaro, Fumè Grigio e Bronzo
Light, Smoky Gray, and Bronze



⁽¹⁾ Lens in relazione al lavabo Eccentrico e al rubinetto Acquifero by Victor Vasilev. Il vetro raffigurato è bronzo; la retroilluminazione standard è 4000K, ordinabile anche a 3000K.

⁽²⁾ Lens paired with the Eccentrico basin and the Acquifero tap by Victor Vasilev. The glass shown is bronze; standard backlighting is 4000K, also available in 3000K.



Ratio

by Massimo Castagna

A modular mirrored cabinet combining hidden storage, precise geometry, and integrated lighting, creating layered reflections, refined order, and an intimate, functional atmosphere for everyday rituals.



^(IT) Specchio contenitore modulare con ante da 20 a 60 cm. Interni disponibili in legno, laccato o melaminico, con luci make-up frontali e pratica presa maniglia inferiore. Fianchi in specchio e metalli di finitura per i laterali a vista. Un sistema infinito, costruito con pochi elementi.

^(EN) Modular mirrored cabinet with doors from 20 to 60 cm. Interiors available in wood, lacquered or melamine finishes, with front make-up lighting and a practical lower grip handle. Mirrored sides and metal finishes for exposed lateral panels. An infinite system, composed of few elements.





Designed it as
unexpected space:
modular storage and
reflections, inner and
outer light shaping
atmosphere, balancing
rigor, function, and
intimate rituals.

Technical Sheets

Mirror Cabinet

H 75 cm

L 20-30-40-60 cm

P 15 cm

Mirror Cabinet with light

H 75 cm

L 60 cm

P 15 cm

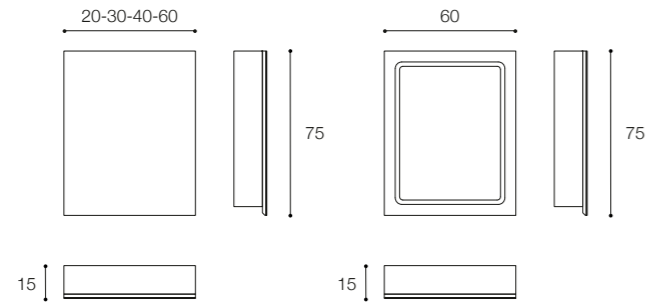

⁽¹⁾ Ratio in relazione al mobile Essenzae al lavabo Invaso. Il dettaglio dell'anta apribile con illuminazione integrata si attiva solo quando è chiusa in posizione specchio.

⁽²⁾ Ratio paired with the Essenza cabinet and the Invaso basin. The detail of the opening door with integrated lighting activates only when closed in mirror position.



Invaso Stone

by Falper Design

Now in marble,
blending harmony,
precision, and
practicality; a rigorous
form defining the ideal
bathroom gesture,
expressing timeless
prestige and refined
balance.





We envisioned Invaso as a pure, essential volume, where water meets stone in perfect proportion, elevating everyday gestures into moments of quiet beauty.

Technical Sheets

H 10 cm
P 45 cm
L 80-100-120 cm

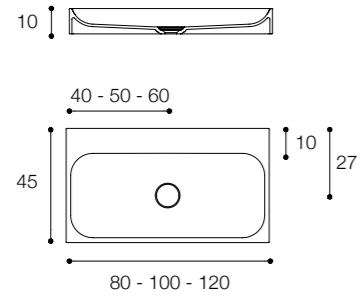

Finiture / Finishes

Marmo | Marble



Goccia

by Massimo Castagna

A marble or solid surface countertop with integrated drip-edge profile, combining strong personality and function, ensuring clean lines, protection, and refined everyday usability.



Technical Sheets

H 3 cm
L 60 - 280 cm
P 45 / 55 cm

Finiture / Finishes

Cristalplant Bio Active
Cristalplant Colors



Marmo | Marble



^(IT) Il top Goccia in marmo è l'optional ideale per la collezione Viaveneto Stone. Il bordo da 8 mm di spessore e la particolare lavorazione ne caratterizzano ulteriormente l'estetica, garantendo al tempo stesso grande praticità.

^(EN) The Goccia marble top is the ideal optional addition for the Viaveneto Stone collection. The 8 mm thick edge and its distinctive processing further define the design, while ensuring practical everyday use.



Boiserie

by Falper Design

Elegant boiserie in American walnut or any Falper wood essence, featuring adjustable systems and special elements, creating a sophisticated, refined architectural interior atmosphere.



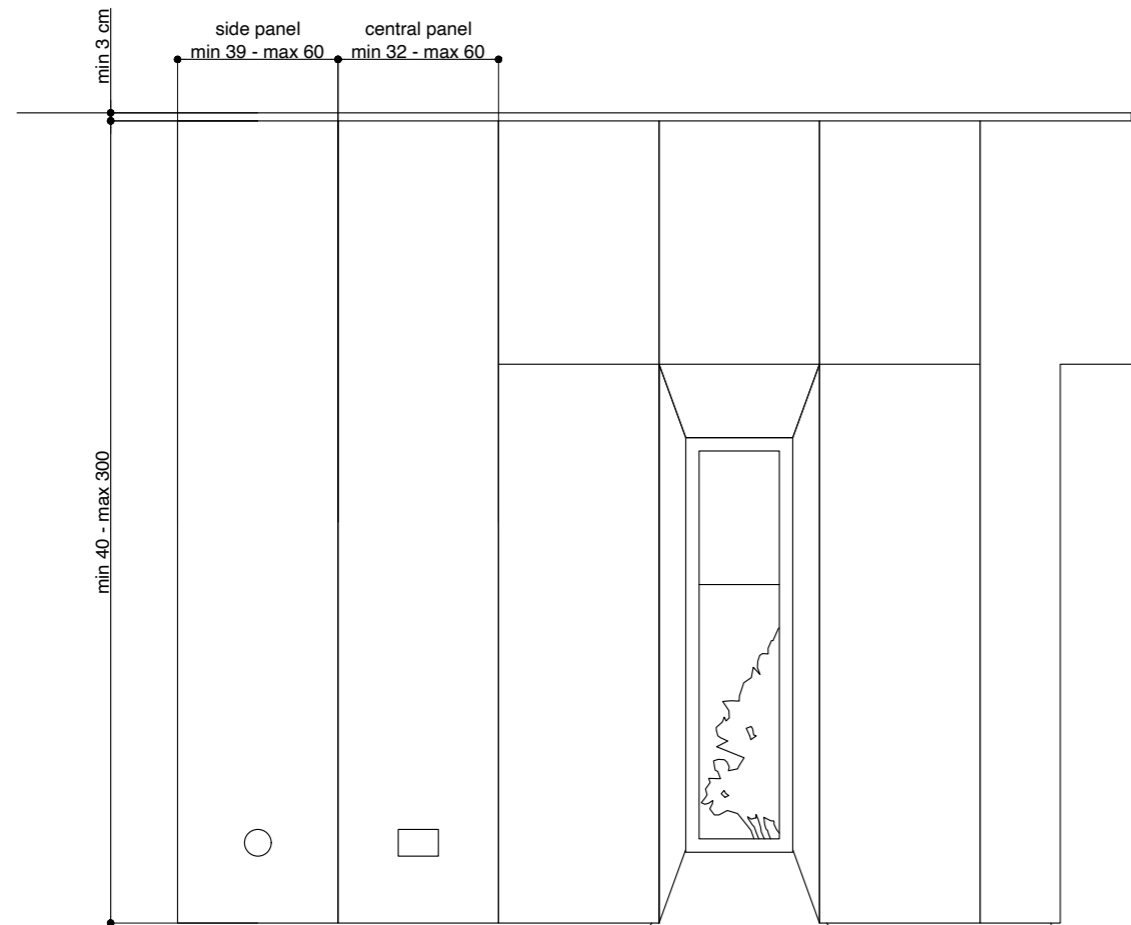

^(IT) Pannelli in legno fino a 300 cm di altezza, configurabili per nicchie, finestre e porte a imbotta, personalizzabili per forma e dimensione. Il sistema prevede una struttura regolabile e uno spessore totale finito di 4 cm.

^(EN) Wood panels up to 300 cm in height, configurable for niches, windows and recessed doors, customisable in shape and size. The system features an adjustable structure with a total finished thickness of 4 cm.

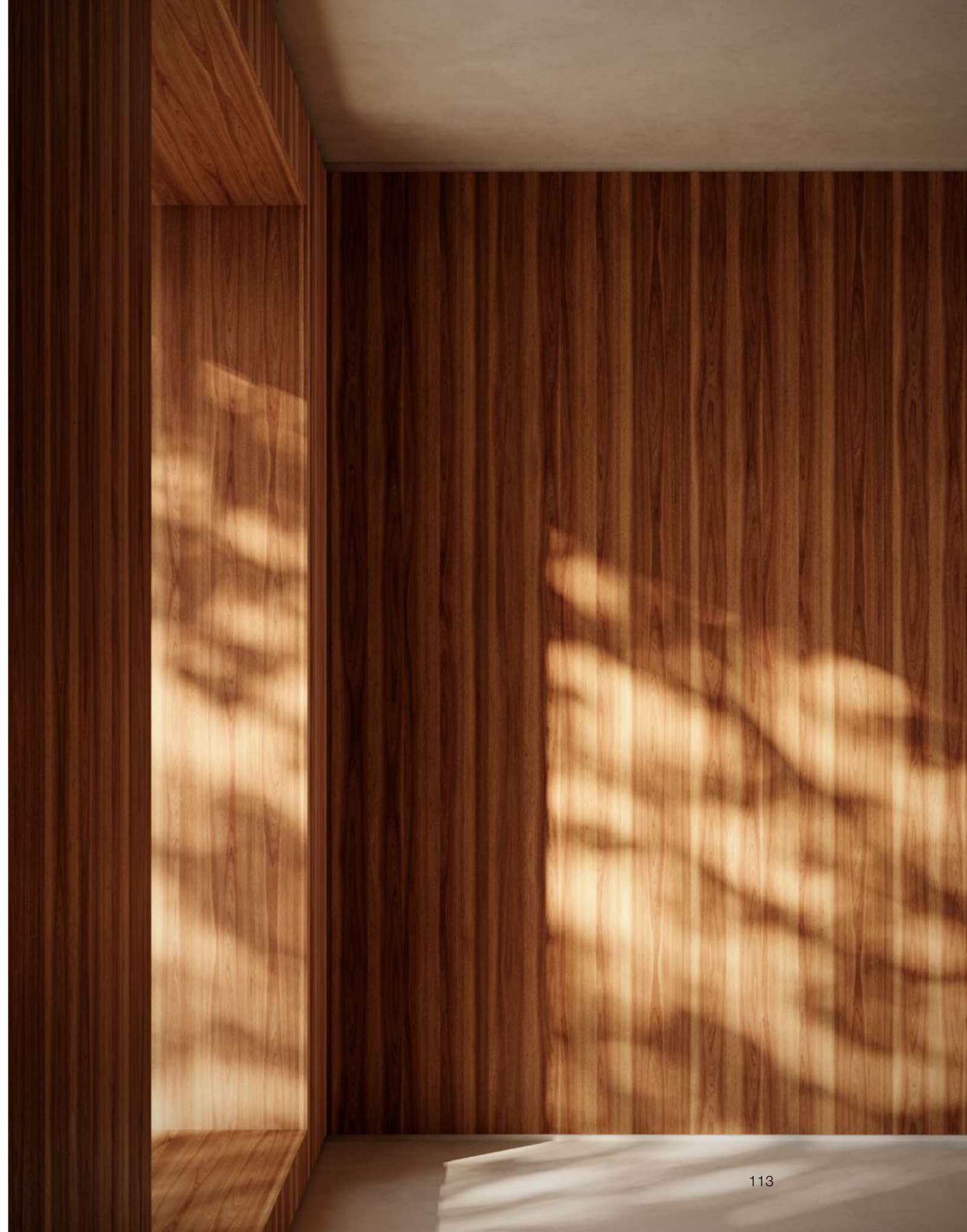

graphic design

bianca previato schiesari
distortion studio

photo

alberto strada
giovanni righetti

3d images

garage 121

products on stage

a selection of complementary
elements featured throughout
the catalogue.

Acquifero and Cilindro taps — design Victor Vasilev

Eccentrico basin — design Victor Vasilev

George mirror — design Falper

Essenza collection — design Falper

Chiaro e Appeso mirror — design Falper

Chiaro e Intero mirror — design Falper

Falper Srl

Via Veneto 7 – 9

40064 Ozzano Emilia, Bologna (Italy)

Tel + 39 051 799319

info@falper.it

falper.it